

› Prototyping Unit for Modelbased Applications

With PUMA, we offer a compact and universal Rapid-Control-Prototyping-Platform optionally with integrated power electronics for the near to production model-based software development with MATLAB/Simulink or dSPACE TargetLink.



Key-Features

- ›› Powerful automotive dual-core microcontroller
- ›› Comprehensive analog- und digital-I/O
- ›› Communication interfaces CAN / FlexRay / LIN
- ›› Integrated universal power stages
- ›› Rated operating voltage 12 - 48 V
- ›› Software design and automatic code generation with MATLAB/Simulink or dSPACE TargetLink
- ›› Comfortable I/O-configuration by a graphical user interface in MATLAB
- ›› CAN-, FlexRay and LIN-configuration via import of DBC-, FIBEX- and LDF-Files
- ›› Application according to ASAP2 via XCP-on-ethernet (e.g. with Vector CANape or PUMA-CMI)
- ›› Available versions:
 - PUMA (without power stage)
 - PUMA-MPI (with Motor Power Inverter)
 - PUMA-PTM (with Power Transistor Module)
 - PUMA-PSI (with Power Stage Interface)

Application Area

The typical application area of PUMA is the model-based software design with MATLAB/Simulink or dSPACE TargetLink, focussing a first near to production function and concept confirmation. Due to optionally integrated power stages, PUMA is predestinated for the control of various electric actuators.

With PUMA, a universal development platform also for field tests with larger test fleets is available at an attractive price/performance ratio.

PUMA

The Logic-ECU PUMA builds the basis of our ECU platform. The computation unit is based on the dual-core microcontroller Freescale MPC5675K. Comprehensive analog and digital interfaces allow the connection of various peripheral devices. Additionally, a powerful FPGA is integrated, that takes over computation time intensive I/O-evaluations.

For the communication with other ECU's, all established automotive communication interfaces like CAN, FlexRay and LIN are available.

An ethernet connection realizes a high data transfer rate via XCP protocol to the Host-PC for application and signal measurement.

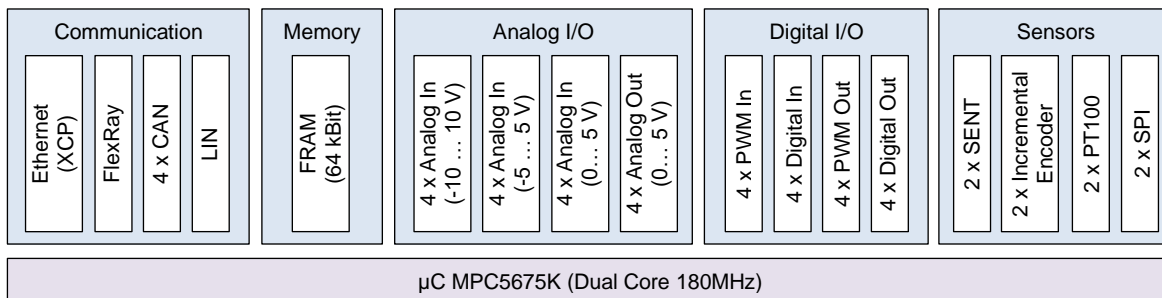

Overview Interfaces and I/O

Key-Features

- » Automotive dual-core microcontroller
- » FPGA for I/O-specific processing algorithms
- » Comprehensive analog- and digital-I/O
- » Special sensor interfaces
- » FRAM with read- and write-access from the application
- » Bussystems CAN, FlexRay and LIN
- » Ethernet-application interface via XCP-protocol (maximum data transfer rate 5 kHz)
- » Rated operating voltage 12 - 48 V

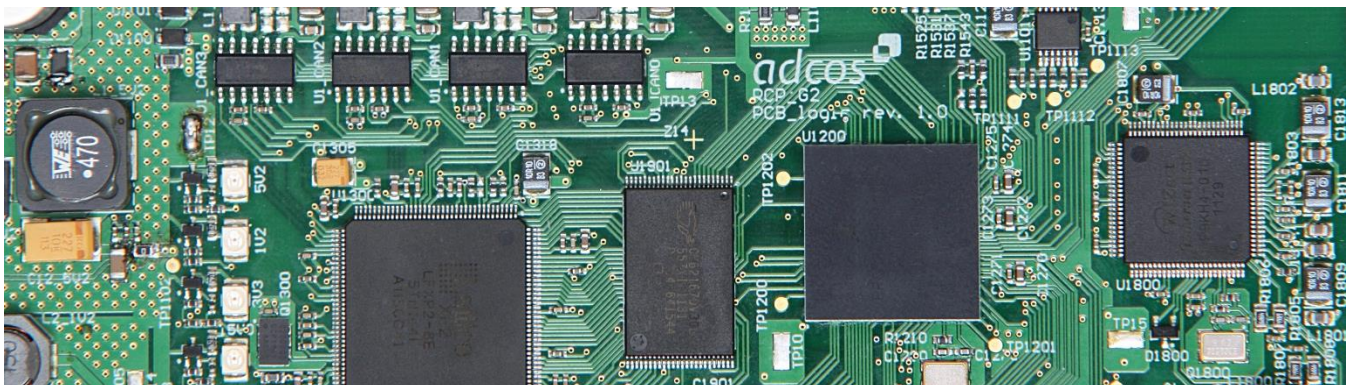

PUMA-MPI

The version PUMA-MPI (Logic-ECU PUMA with Motor Power Inverter) comes with an integrated high current power stage for the operation of electronically commutated 3-phase motors. This power stage is equipped with numerous sensors for the measurement of all relevant voltages, currents and temperatures. Additionally, a precharge stage, an inverse polarity protection and an EMC-filter are integrated.

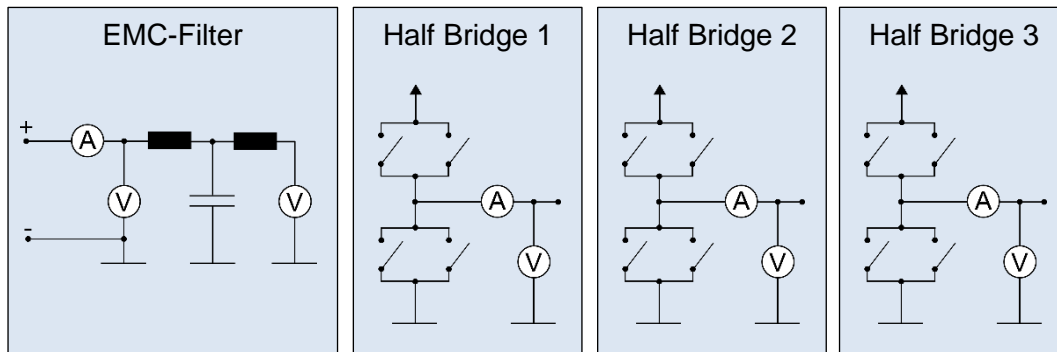

Block diagram MPI

Key-Features

- » B6-Bridge
 - » Setup with 3 discrete half bridges
 - » Parallel mosfets for higher current carrying capacity
 - » Nominal current motor phases: +/- 150 A
 - » Maximum current motor phases: +/- 240 A
- » Sensors
 - » Currents and voltages: U-, V-, W-phases and DC-link
 - » Temperatures: PCB at U-, V-, W-phases
- » DC-Link
 - » Nominal voltage range: 12 - 48 V
 - » Maximum permitted voltage range: 7 - 58 V
 - » Precharge stage, inverse polarity protection and EMC-filter
- » Computation unit identical to PUMA



PUMA-PTM

The version PUMA-PTM (Logic-ECU PUMA with Power Transistor Module) offers an integrated power stage with 4 identical high-power half bridges and 4 identical low-power half bridges for the control of various actuators. All relevant voltages, currents and temperatures are measured. A precharge stage, an inverse polarity protection and an EMC-filter are also integrated.

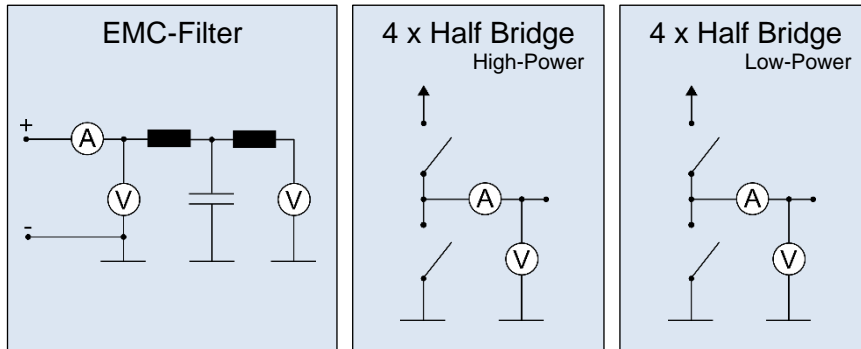

Block diagram PTM

Key-Features

- » 4 identical High-Power Half Bridges
 - » combinable as e.g. H-bridges or B6-bridge
 - » Nominal current: +/-50 A
 - » Maximum current: +/-70 A
- » 4 identical Low-Power Half Bridges
 - » combinable as e.g. H-bridges or B6-bridge
 - » Nominal current: +/- 7.5 A
 - » Maximum current: +/- 9.0 A
- » Sensors
 - » Currents and voltages: Half bridges and DC-Link
 - » Temperatures: PCB at three thermal relevant positions
- » DC-Link
 - » Nominal voltage range: 12 - 48 V
 - » Maximum permitted voltage range: 7 - 58 V
 - » Precharge stage, inverse polarity protection and EMC-filter
- » Computation unit identical to PUMA



PUMA-PSI

The version PUMA-PSI (Logic-ECU PUMA with Power Stage Interface) provides an integrated interface for controlling external power stages. The interface is realized by highly configurable PWM outputs for controlling the power semiconductors and PWM synchronous analog inputs for current and voltage measurement. Due to the complete galvanic isolation of the interface PUMA-PSI is also suitable for the control of high-voltage power stages. The software development and configuration of the interface is done as usual in MATLAB / Simulink.

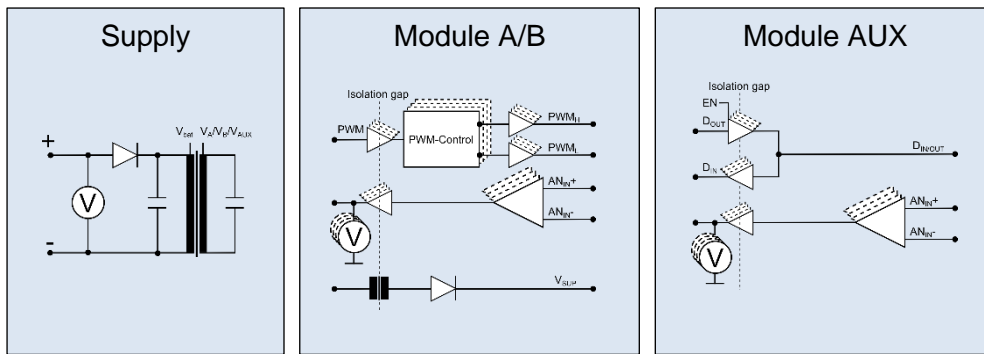

Block diagram PSI

Key-Features

- » 8x2 PWM outputs (each low und high) for control of a total of 8 half bridges
- » 8 PWM-synchronous triggered analog inputs for current and voltage measurement
- » Ideally suited for software development and testing of electric drive units (inverter and motor)
- » Full galvanic isolation of all inputs and outputs of the power stage interface
- » SW-configurable PWM frequency from 100Hz to 100kHz
- » SW-configurable inverter dead times to avoid electric short circuits
- » SW-configurable measurement sample points for PWM-synchronous triggered analog inputs
- » Setting the duty cycles and Tri-States for each half bridge in Simulink
- » Configuration of the complete interface with PUMA-RTI
- » Computation unit identical to PUMA



Software Architecture

The customer application is designed model based with MATLAB/Simulink or dSPACE TargetLink and implemented by automatic code generation. The linkage of the customer application software with the embedded software is realized by a run-time interface with a standardized software interface.

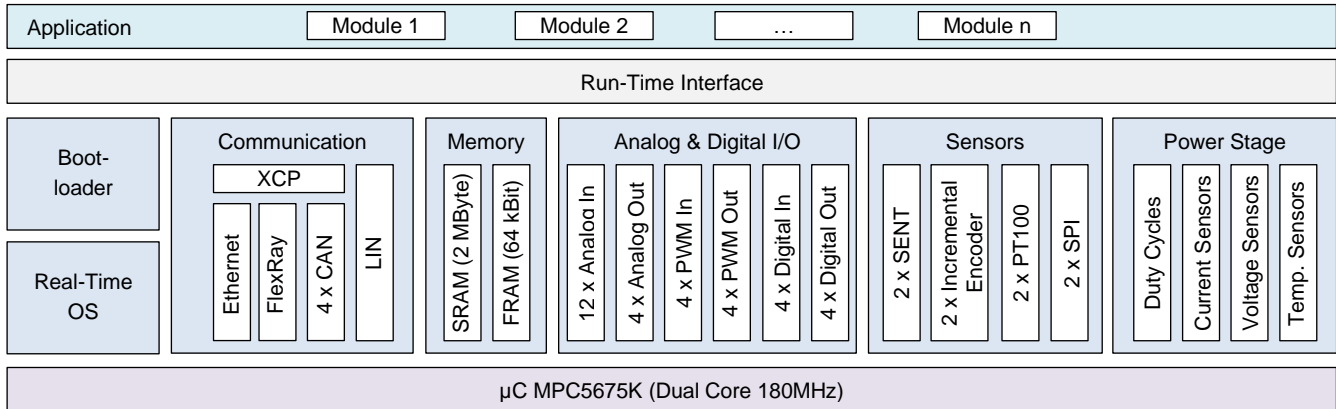

Software Architecture

The embedded software below the application layer is supplied as a modular software package by us. This package contains the real-time operating system and the bootloader for flashing applications. The driver libraries implement the communication and memory connectivity as well as the access to the analog and digital interfaces, sensors and power stages.

PUMA RTI

The PUMA Run-Time Interface (RTI) realizes the interface between the embedded software and the customer application, which is designed in MATLAB/Simulink or dSPACE TargetLink.

The configuration and generation of this interface is simple using a graphical user interface in MATLAB. Therein, the I/O signals and sensors used in the customer application, the memory access to the nonvolatile memory (FRAM), and the power electronics are configured. Likewise, CAN, FlexRay or LIN bus communications are defined by import of DBC-, FIBEX- or LDF-files.

After completing the configuration corresponding Simulink interface blocks are provided, which are integrated in the customer's application by drag and drop and thus produce the linkage of the model based application with the embedded software.

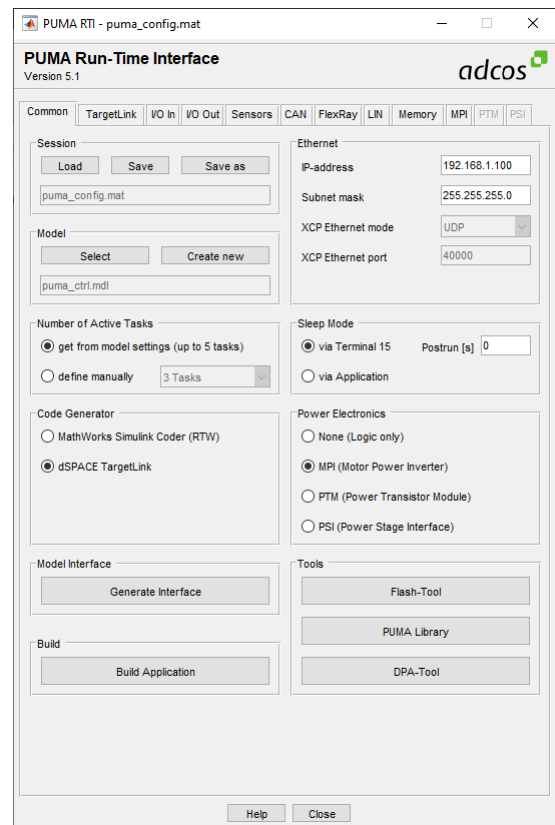

PUMA RTI supports the automatic code generation with Simulink Coder (former: Real-Time Workshop) and with dSPACE TargetLink.

When using the Simulink Coder, the user can use all the capabilities of Simulink such as discrete-time or continuous-time models or multi-rating.

When using dSPACE TargetLink, likewise all TargetLink features can be used. For auto code generation, the model of the customer application is parsed by pressing a button for TargetLink code generation units, whereby each of them gets implemented as a separate C-function. In the graphical user interface of PUMA RTI, each C-function is assigned to individual real-time tasks and their calling sequence inside each task is defined.

The connection of the code generation units in the model to the PUMA embedded software is done as usual by linking the TargetLink inport and outport blocks with the data dictionary (DD). Therefore, any DD-file can be specified in PUMA-RTI. The variables required for the linkage to the embedded software are created automatically in the DD by pressing a button.

Likewise, fixed point scaled code generation units can be implemented on PUMA, too. Thus, the developed software can be implemented without any detours on the later production ECU and PUMA can be used for further parallel development.

Another advantage of the PUMA RTI development environment is provided in terms of software qualification and quality assurance. All PUMA interface blocks used in Simulink are implemented in a way, that the customer application can be linked closed-loop to a simulation model of the plant. In this manner, the same model can be used for both, automatic code generation and MIL / SIL simulation.

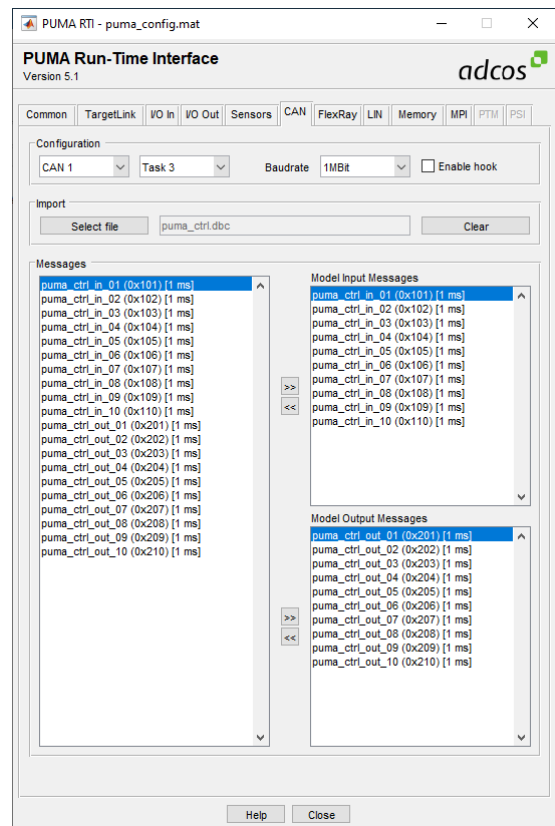
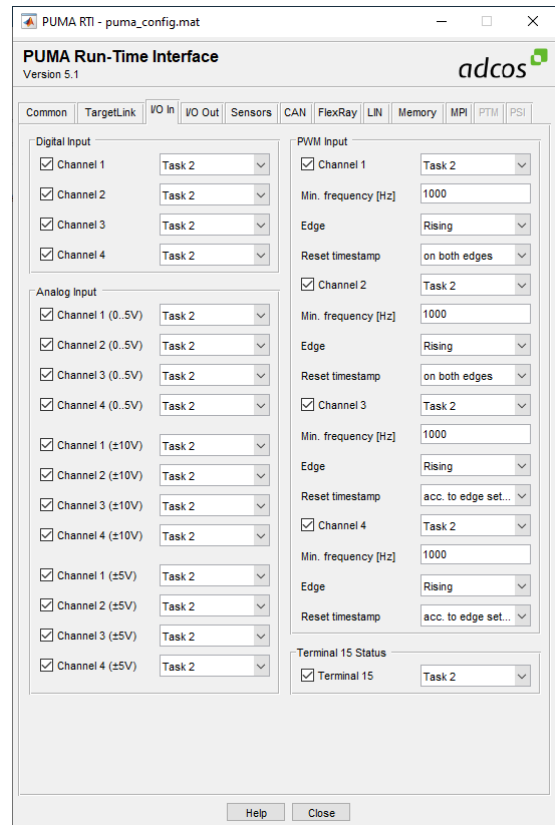

Application

The application and flashing of PUMA is realized according to ASAP2 via the standardized XCP protocol. Therefore, an ethernet interface is available that allows high data transfer rates of up to 5 kHz with a large number of signals. Tools with XCP support like Vector CANape or PUMA-CMI can be used for application.

PUMA-CMI

Included with the PUMA software, we also provide the tool PUMA-CMI (Calibration and Measurement Interface), which enables online calibration of parameters as well as data visualization and recording. The tool allows customization of any number of tabs. Measurement data are stored in HDF5 format and can be imported easily in MATLAB for further analysis. The connection to the PUMA hardware is as usual via an Ethernet connection.

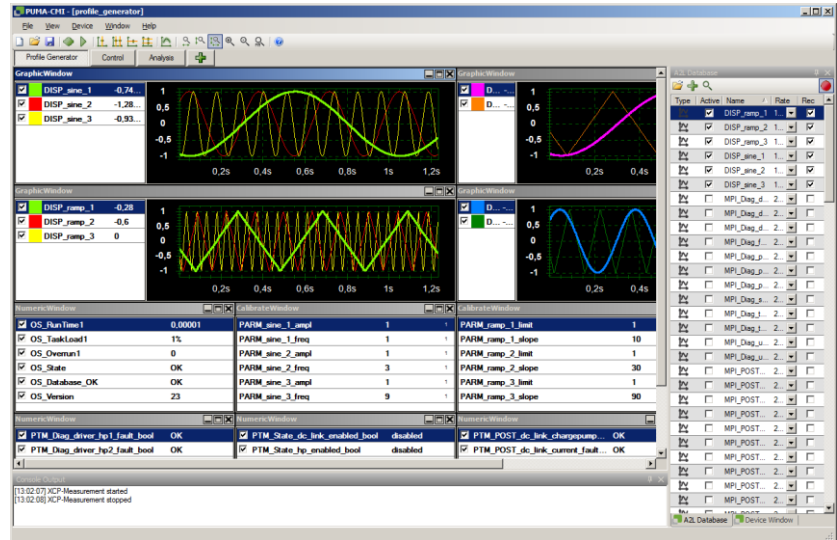

Key-Features

- » Calibration and measurement via Ethernet interface on PUMA Hardware
- » Visualization and recording up to 5 kHz
- » Storage of measured data in HDF5 format (compatible with MATLAB for data analysis)
- » Simple and intuitive operation
- » Free design of surfaces (multi-tab)
- » Graphical and / or numerical display of measurement data
- » Numeric input of calibration values
- » Additional measurement tools (X / Y cursor, statistical functions, spike detection)



We offer our development platform in the variants PUMA (pure Logic-ECU), PUMA-MPI (PUMA with integrated Motor Power Inverter), PUMA-PTM (PUMA with integrated Power Transistor Module) and PUMA-PSI (PUMA with integrated Power Stage Interface).

PUMA	
	
Microcontroller	Freescall Qorivva MPC5675K Dual Core, 180MHz CPU-clock frequency
Memory	SRAM 512 kByte (processor-internal), 2048 kByte (external) Flash 2048 kByte NVRAM 8 kByte
FPGA	Lattice XP2-8E
Bus Systems	4 x CAN (wake-up capable) 1 x FlexRay (wake-up capable) 1 x LIN
I/O-Interfaces	4 x Analog In (differential) -10 ... 10 V 4 x Analog In (differential) -5 ... 5 V 4 x Analog In (single-ended) 0 ... 5 V 4 x Analog Out (single-ended) 0 ... 5 V 4 x PWM In frequency 1 Hz ... 1 MHz 4 x PWM Out frequency 230 Hz ... 100 kHz 4 x Digital In 0 ... 5 V 4 x Digital Out 0 ... 5 V
Sensor-Interfaces	2 x Quadrature-encoder (1 x differential, 1 x single-ended) 2 x PT-100 2 x SENT 1 x SPI 2 x 5 V SENT sensor supply (switchable) 2 x 5 V digital sensor supply (switchable) 2 x 5 V analog sensor supply (switchable) 2 x Usupply sensor supply (switchable)
Application Interfaces	XCP-on-ethernet 100 Mbit/s, maximum data transfer rate 5kHz Optionally: XCP-on-CAN or XCP-on-FlexRay
Operating Environment	Nominal voltage range: 12 ... 48 V Maximum permitted voltage range: 7 ... 58 V Wake-Up capability via terminal 15, CAN, FlexRay Temperature range: -40° ... 85°C Aluminum casing, splash- and dustproof
Connectors	Communication, I/O and sensors: D-SUB HD 44 pin and D-SUB HD 62 pin Ethernet: RJ-45
Dimensions (w x h x d)	194 x 52 x 123 mm (without mounting holes) 219 x 52 x 123 mm (with mounting holes) The distances of the M5 mounting holes are 207 x 102 mm The height of the base plane is 5 mm

PUMA-MPI



Computation Unit	See PUMA
Inverter	B6-bridge with parallel Mosfets Nominal current motor phases: +/- 150 A Maximum current motor phases: +/- 240 A Switching frequency Mosfets: 5 kHz, 10 kHz or 20 kHz
Internal Sensors	Currents: U-, V-, W-phases and DC-link Voltages: U-, V-, W-phases, DC-link and supply Temperatures: PCB at U-, V-, W-phases
Operating Environment	Nominal voltage range: 12 V ... 48 V Maximum permitted voltage range: 7 V ... 58 V Reverse polarity protection Precharge stage for DC-link capacitors EMC DC-link filter Temperature range: -40° ... 125°C Aluminum casing, splash- and dustproof
Connectors	5 x M8 ring connector (2 x supply +/- and 3 x motor phases U V W)
Dimensions (w x h x d)	194 x 65 x 123 mm (without mounting holes) 219 x 65 x 123 mm (with mounting holes) The distances of the M5 mounting holes are 207 x 102 mm The height of the base plane is 5 mm

PUMA-PTM



Computation Unit	See PUMA
High-Power Half Bridges	<p>4 x Half bridge, operatable in any combination (e.g. 2 x H-bridge or 1 x B6-bridge and 1 x Half bridge)</p> <p>Nominal current per half bridge: +/- 50 A</p> <p>Maximum current per half bridge: +/- 70 A</p> <p>Switching frequency mosfets: 5 kHz, 10 kHz or 20 kHz</p>
Low-Power Half Bridges	<p>4 x Half bridge, operatable in any combination (e.g. 2 x H-bridge or 1 x B6-bridge and 1 x Half bridge)</p> <p>Nominal current per half bridge: +/- 7.5 A</p> <p>Maximum current per half bridge: +/- 9.0 A</p> <p>Switching frequency mosfets: 5 kHz, 10 kHz or 20 kHz</p>
Internal Sensors	<p>Currents: Half bridges and DC-link</p> <p>Voltages: Half bridges, DC-link and supply</p> <p>Temperatures: 3 x PCB</p>
Operating Environment	<p>Nominal voltage range: 12 V ... 48 V</p> <p>Maximum permitted voltage range: 7 V ... 58 V</p> <p>Reverse polarity protection</p> <p>Precharge stage for DC-link capacitors</p> <p>EMC DC-link filter</p> <p>Temperature range: -40° ... 125°C</p> <p>Aluminum casing, splash- and dustproof</p>
Connectors	<p>7 x M6 ring connectors and 4 x M4 ring connectors</p> <p>(2 x supply +/-, 4 x high-power phases, 4 x low-power phases, 1 x low-power plus)</p>
Dimensions (w x h x d)	<p>194 x 65 x 123 mm (without mounting holes)</p> <p>219 x 65 x 123 mm (with mounting holes)</p> <p>The distances of the M5 mounting holes are 207 x 102 mm</p> <p>The height of the base plane is 5 mm</p>

PUMA-PSI



Computation Unit	See PUMA
Module A / B	<p>4 x PWM outputs 0 V ... 5 V (each PWM-output consist of PWM+ and PWM-)</p> <p>PWM-frequency-range: 100 Hz to 100 kHz</p> <p>Selectable dead-time between PWM+ and PWM- (0 ns to 10 ms; step 10 ns)</p> <p>4 x Differential-Analog-Inputs with selectable range</p> <p>Selectable Analog-Input-Range: ± 10 V, ± 5 V, ± 1 V or 0 V ... 5 V</p> <p>1 x 5 V sensor supply (not switchable)</p>
Module AUX	<p>4 x General-Purpose-Digital-Input/Output 0 V ... 5 V</p> <p>4 x Differential-Analog-Inputs with selectable range</p> <p>Selectable Analog-Input-Range: ± 10 V, ± 5 V, ± 1 V or 0 V ... 5 V</p>
Isolation	<p>Each Module A, B and AUX is galvanic isolated to each other and to the logic part of the PUMA.</p> <p>Continuous working voltage across isolation barrier: 60 VDC / 42.5 VAC</p> <p>1-second-flash-test: 1 kVrms</p>
Internal Sensors	Voltages: supply voltage
Operating Environment	<p>Nominal voltage range: 12 V ... 48 V</p> <p>Maximum permitted voltage range: 7 V ... 58 V</p> <p>Reverse polarity protection</p> <p>Temperature range: -40° ... 85°C</p> <p>Aluminum casing, splash- and dustproof</p>
Connectors	<p>2 x D-SUB HD 26 pin (Module A and B)</p> <p>1 x D-SUB HD 15 pin (Module AUX)</p>
Dimensions (w x h x d)	<p>194 x 65 x 123 mm (without mounting holes)</p> <p>219 x 65 x 123 mm (with mounting holes)</p> <p>The distances of the M5 mounting holes are 207 x 102 mm</p> <p>The height of the base plane is 5 mm</p>